



## Preparadora de Pedidos JX0

Ligero y flexible;

Batería AGM (sin mantenimiento), **Batería ION Litio como opción.**

- Altura Máx de la plataforma: 2,99 m.
- Tamaño del equipo: 1365x1440x750 mm., radio de giro (1260mm.), adecuado para espacios estrechos
- Aumentá la eficiencia en el Depósito de mercaderías.
- Mástil extremadamente estable
- Para preparación de pedidos de menor volumen y en el entorno del Retail.

# Preparadora de Pedidos JX0

|                     |                  |  |   |       |                           |                           |
|---------------------|------------------|--|---|-------|---------------------------|---------------------------|
| Distinguishing mark | 1.1              | Manufacturer                                 |   |       | EP                        | EP                        |
|                     | 1.2              | Model designation                            |   |       | JX0(Li-ion)               | JX0                       |
|                     | 1.3              | Drive unit                                   |   |       | Electric                  | Electric                  |
|                     | 1.4              | Operator type                                |   |       | Order-picker              | Order-picker              |
|                     | 1.5              | Rated capacity                               | Q   | kg    | 90/110/136                | 90/110/136                |
|                     | 1.6              | Load center distance                         | c   | mm    | —                         | —                         |
|                     | 1.8              | Load distance □ centre of drive axle to fork | x   | mm    | —                         | —                         |
|                     | 1.9              | Wheelbase                                    | y   | mm    | 1095                      | 1095                      |
|                     | Service weight   | 2.1  | Service weight                              |       |                           | 800                       |
| 2.2                 |                  | Axle loading, laden front/rear               |   |       | 590/410                   | 590/410                   |
| 2.3                 |                  | Axle loading, unladen front/rear             |   |       | 380/420                   | 380/420                   |
| Tyres/chassis       | 3.1              | Tyre type                                    |   |       | Polyurethane/Solid rubber | Polyurethane/Solid rubber |
|                     | 3.2              | Tyre size, front                             |   | mm    | Φ210×70                   | Φ210×70                   |
|                     | 3.3              | Tyre size, rear                              |   | mm    | Φ250×100                  | Φ250×100                  |
|                     | 3.4              | Additional wheels                            |   | mm    | Φ74×48                    | Φ74×48                    |
|                     | 3.5              | Wheels, number front/rear (x=drive wheels)   |   | mm    | 1x2/2                     | 1x2/2                     |
|                     | 3.6              | Tread, front                                 | b10   | mm    | 545                       | 545                       |
|                     | 3.7              | Tread, rear                                  | b11   | mm    | 640                       | 640                       |
| Dimensions          | 4.2              | Height, mast lowered                         | h1  | mm    | 1365                      | 1365                      |
|                     | 4.3              | Free lift                                    | h2  | mm    | 485                       | 485                       |
|                     | 4.4              | Lift height                                  | h3  | mm    | 3485                      | 3485                      |
|                     | 4.5              | Height, mast extended                        | h4  | mm    | 4365                      | 4365                      |
|                     | 4.7              | Height of overhead/ guard cabin              | h6  | mm    | 1410                      | 1410                      |
|                     | 4.8              | Seat height/standing height                  | h7  | mm    | 285                       | 285                       |
|                     | 4.14             | Stand height, elevated                       | h12   | mm    | 3000                      | 3000                      |
|                     | 4.15             | Lowered height                               | h13   | mm    | —                         | —                         |
|                     | 4.19             | Overall length                               | l1  | mm    | 1440                      | 1440                      |
|                     | 4.20             | Length to face of forks                      | l2  | mm    | —                         | —                         |
|                     | 4.21             | Overall width                                | b1/b2                                       | mm    | 750                       | 750                       |
|                     | 4.22             | Fork dimensions                              | s/e/l                                       | mm    | —                         | —                         |
|                     | 4.25             | Distance between fork-arms                   | b5  | mm    | —                         | —                         |
|                     | 4.32             | Ground clearance, center of wheelbase        | m2  | mm    | 35                        | 35                        |
|                     | Performance data | 4.34.1                                       | Aisle width for pallets 1000×1200 crossways | Ast   | mm                        | —                         |
| 4.34.2              |                  | Aisle width for pallets 800×1200 crossways   | Ast   | mm    | —                         | —                         |
| 4.35                |                  | Turning radius                               | Wa  | mm    | 1260                      | 1260                      |
| 5.1                 |                  | Travel speed, laden/unladen                  |   | km/h  | 6/6.5                     | 6/6.5                     |
| 5.2                 |                  | Lifting speed, laden/unladen                 |   | m/s   | 0.22/0.27                 | 0.22/0.27                 |
| 5.3                 |                  | Lowering speed, laden/unladen                |   | m/s   | 0.31/0.25                 | 0.31/0.25                 |
| 5.8                 |                  | Max. gradeability, laden/unladen             |   | %     | 5/8                       | 5/8                       |
| Electric-engine     | 5.10             | Service brake                                |   |       | Electromagnetic           | Electromagnetic           |
|                     | 6.1              | Drive motor rating S2 60 min                 |   | kW    | 0.65                      | 0.65                      |
|                     | 6.2              | Lift motor rating at S3 15%                  |   | kW    | 2.2                       | 2.2                       |
|                     | 6.4              | Battery voltage/nominal capacity             |   | V/Ah  | 24V/120                   | 24V/120                   |
|                     | 6.5              | Battery weight                               |   | kg    | 50                        | 71                        |
| Addition data       | 8.1              | Type of drive unit                           |   |       | DC                        | DC                        |
|                     | 10.5             | Steering design                              |   |       | Electronic                | Electronic                |
|                     | 10.7             | Sound pressure level at the driver's ear     |   | dB(A) | 60                        | 60                        |

If there are improvements of technical parameters or configurations, no further notice will be given.  
The diagram shown may contain non-standard configurations.

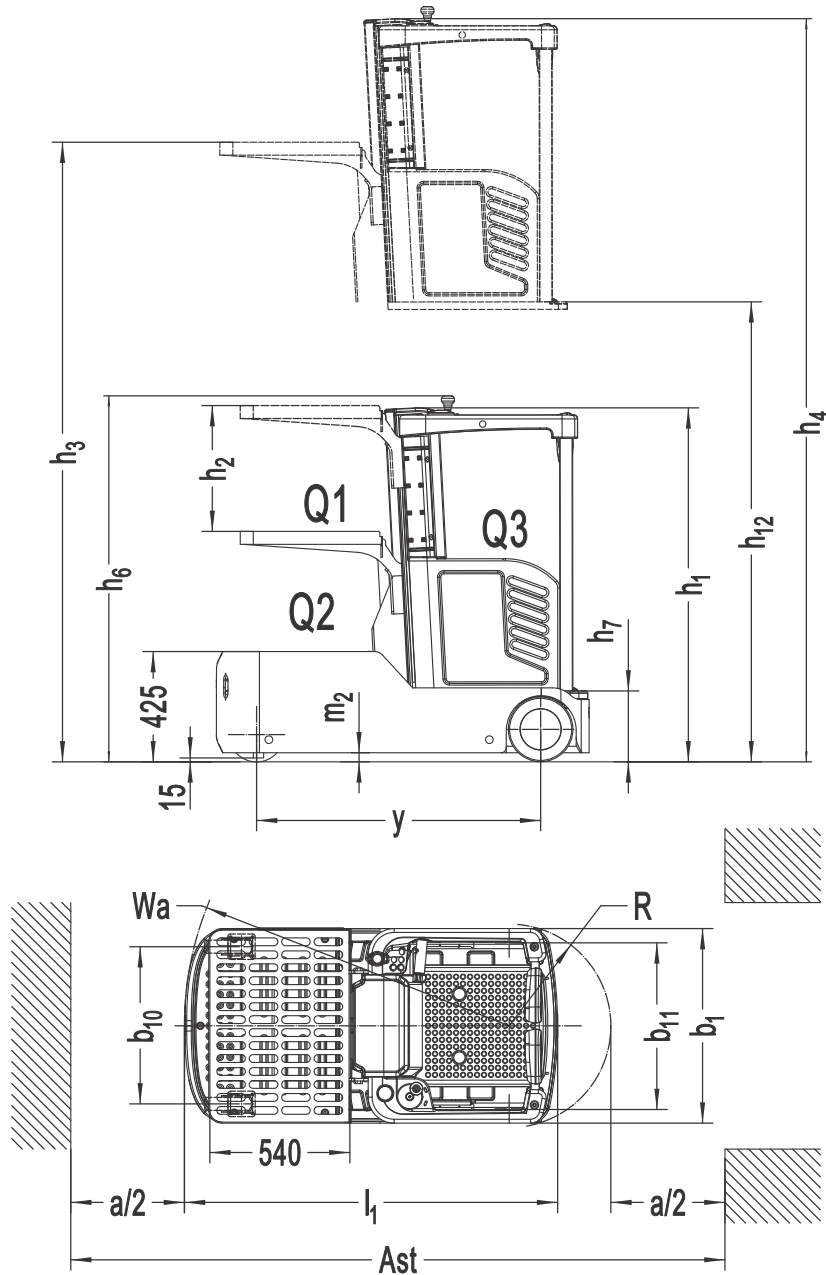

## Opcionales

| No.  | Optional items                           | JX0                         |
|------|--|-----------------------------|
| 2.1  | Load wheel type                          | ●Single                     |
| 2.2  | Load wheel material                      | ●PU                         |
| 2.3  | Drive wheel material                     | ●PU                         |
| 2.7  | Battery capacity                         | ●120Ah                      |
| 2.8  | Charger                                  | ●24V-15A External           |
| 2.9  | Battery indicator                        | ●With time                  |
| 3.3  | Castor wheels                            | ●Yes and not customized     |
| 3.9  | Blue lamp                                | ●Front blue lamp            |
| 3.12 | Hummer                                   | ●Lowering○Driving○Reversing |
| 3.18 | Guide wheel                              | ●No○Yes and not customized  |
| 3.20 | Step on the safety switch with both feet | ●No○Yes and not customized  |
| 4.7  | Overhead guard                           | ●No                         |

Note: ●Standard ○Optional - Inconformity